

ARI-SAFE-SN ANSI (Semi-Nozzle) - Full lift safety valve D/G, Standard safety valve F

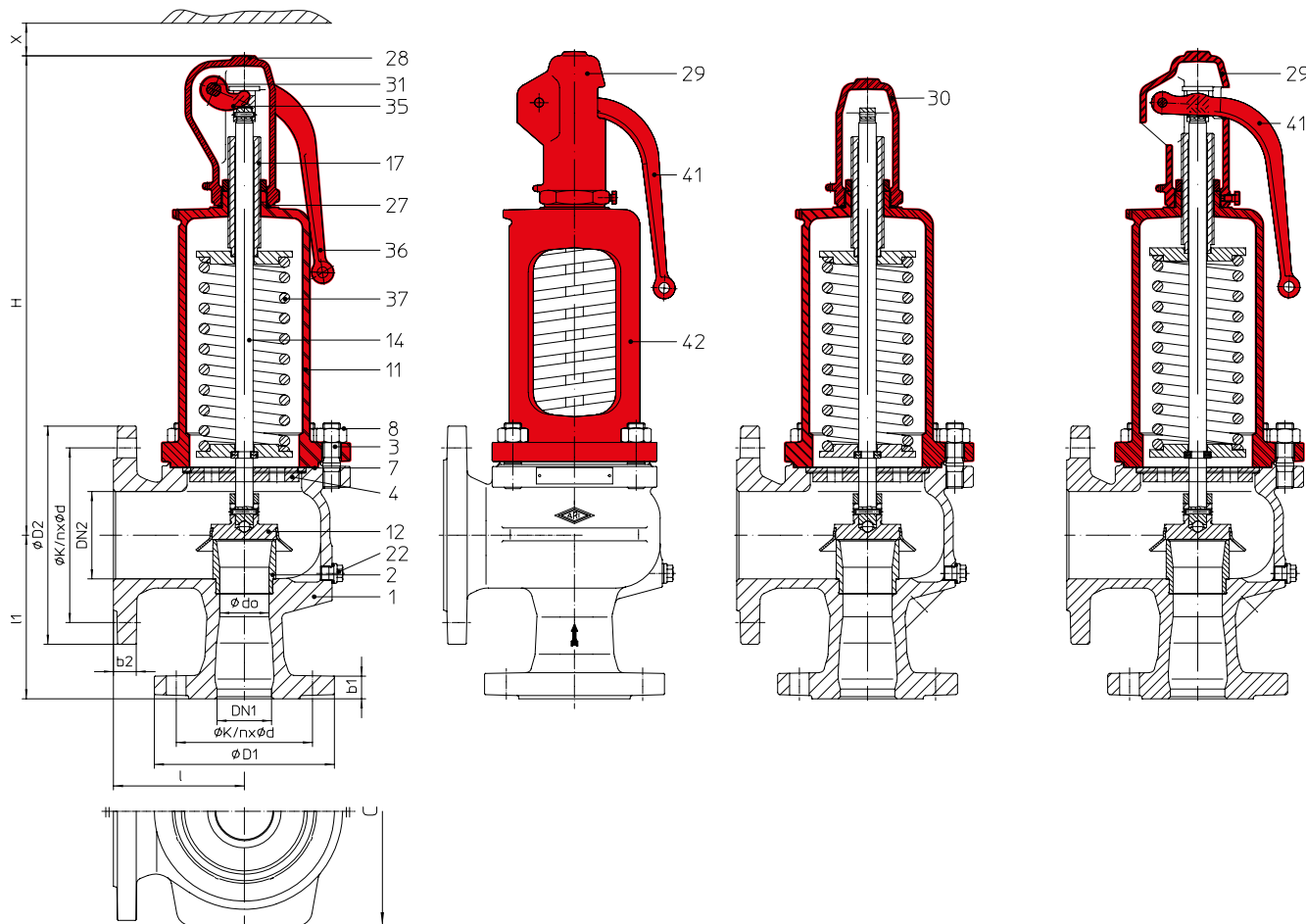

Fig. ... 901
closed lifting device,
closed bonnet

Fig. ... 902
open lifting device,
open bonnet

Fig. ... 911
gastight cap,
closed bonnet

Fig. ... 912
open lifting device,
closed bonnet

Figure	Nominal pressure	Material	Nominal diameter	Temperature range	Flange
32.901 / 902 / 911 / 912	ANSI150/150	SA216 WCB	1" x 2" - 6" x 10"	-29°C to +425°C	ASME B16.5
35.901 / 902 / 911 / 912	ANSI300/150	SA216 WCB	1" x 2" - 6" x 10"	-29°C to +425°C	ASME B16.5
52.901 / 911	ANSI150/150	SA351 CF8M	1" x 2" - 6" x 10"	-60°C to +400°C	ASME B16.5
55.901 / 911	ANSI300/150	SA351 CF8M	1" x 2" - 6" x 10"	-60°C to +400°C	ASME B16.5

Type-test approval

Full lift safety valve: (acc. to VdTÜV-leaflet 663)	Fig. 901/902/911/912	TÜV · SV · . . -663 · D/G
Standard safety valve:	Fig. 901/911	TÜV · SV · . . -663 · F

Construction / Application

Safety valve, spring loaded, direct loaded; steam, gases, vapours and liquids

Requirement

acc. to DIN EN ISO 4126-1 / TRD 421 / AD2000-A2

Sizing

Calculation acc. to EN ISO 4126-1, TRD 421 and AD-leaflet A2

Details required

Medium: Gas	Mass flow (kg/h), molar mass (kg/kmol), temperature (°C), set pressure (bar), back gauge pressure (bar)
Medium: Liquid	Mass flow (kg/h), density (kg/m ³), viscosity, temperature (°C), set pressure (bar), back gauge pressure (bar)

Order data:

ARI-SAFE-SN ANSI - safety valve, Figure ..., Nominal diameter .../..., ANSI ..., Material ..., Set pressure ... bar

	standard: without metal bellows	1" x 2" - 6" x 10" optional: with metal bellows (refer to page 42)
Superimposed back pressure	no backpressure allowed	on request
Built up back pressure	max. 10% from set pressure (gauge) (higher on request)	on request

Parts				
Pos.	Sp.p.	Description	Fig. 32.901/902/911/912; 35.901/902/911/912	Fig. 52.901/911; 55.901/911
1		Body	SA216 WCB	SA351 CF8M
2		Seat	SA479 Gr.316 Ti	SA479 Gr.316 Ti
3		Studs	SA193 B7	SA193 B8
4	x	Spindle guide	NPS ≤ 2": SA276 Gr.420; NPS > 2": SA395 / SA276 Gr.440	NPS ≤ 2": SA479 Gr.316 Ti; NPS > 2": SA351 CF8M
7	x	Gasket	GRAPHIT (CrNi laminated with graphite)	
8		Hexagon nut	SA194 2H	SA194 8
11		Bonnet, closed	SA395	SA351 CF8M
12	x	Disc	SA276 Gr.440	SA479 Gr.316 Ti
14	x	Spindle	SA276 Gr.420	SA479 Gr.316 Ti
17		Adjusting screw	SA276 Gr.420	SA479 Gr.316 L
22		Plug screw (optional)	SA193-B7	SA193-B8
27	x	Sealing ring	CuFA	SA479 Gr.316 Ti
28		Cap, closed	SA395	SA351 CF8M
29		Cap, open	SA395	--
30		Cap, gastight	SA395	SA351 CF8M
31	x	Packing ring	GRAPHIT	
35		Lift fork	SA395	SA351 CF8M
36		Lever, closed	SA395	SA479 Gr.316 Ti
37	x	Spring	SA401 Gr.9254, SA29 Gr.6150	SA313 Gr.316
41		Lever, open	SA395	--
42		Bonnet, open	SA395	--
43		Bellows (optional)	EPDM 70 Shore A	
55		Stainless steel bellows unit (optional)	SA240 / SA479 Gr.316 Ti	SA240 / SA479 Gr.316 Ti
70		Balanced piston	SA240 Gr.316 Ti	SA479 Gr.316 Ti
	L Spare parts			

Coefficient of discharge Kdr		VdTÜV (Values for D/G variabel: 1" - 4" < 3,5 bar, 6" < 4,0 bar)							
NPS		1"x2"	1 1/2"x2" 1 1/2"x2 1/2"	1 1/2"x3"	2"x3"	3"x4"	4"x6"	6"x8"	6"x10"
TÜV · SV · . . -663 · D/G	(bar)	0,74						0,70	
TÜV · SV · . . -663 · F	(bar)	0,54				0,48		0,45	

Pressure-temperature-ratings			Intermediate values for max. permissible operational pressures can be determined by linear interpolation of the given temperature / pressure chart.											
acc. to ASME 16.34			-29°C bis 38°C	50°C	100°C	150°C	200°C	250°C	300°C	325°C	350°C	375°C	400°C	425°C
SA216WCB	ANSI150	(bar)	19,6	19,2	17,7	15,8	13,8	12,1	10,2	9,3	8,4	7,4	6,5	5,5
SA216WCB	ANSI300	(bar)	51,1	50,1	46,6	45,1	43,8	41,9	39,8	38,7	37,6	36,4	34,7	38,8
acc. to ASME 16.34			-60°C bis 38°C	50°C	100°C	150°C	200°C	250°C	300°C	325°C	350°C	375°C	400°C	425°C
SA351CF8M	ANSI150	(bar)	19	18,4	16,2	14,8	13,7	12,1	10,2	9,3	8,4	7,4	6,5	--
SA351CF8M	ANSI300	(bar)	49,6	48,1	42,2	38,5	35,7	33,4	31,6	30,9	30,3	29,9	29,4	--

Information / restriction of technical rules need to be observed!

A production permission acc. to TRB 801 No. 45 is available.

The engineer, designing a system or a plant, is responsible for the selection of the correct valve.

Resistance and fitness must be verified (contact manufacturer for information, refer to Product overview and Resistance list).

NPS	1"x2"	1 1/2"x2"	1 1/2"x2 1/2"	1 1/2"x3"	2"x3"	3"x4"	4"x6"	4"x6"	6"x8"	6"x10"
-----	-------	-----------	---------------	-----------	-------	-------	-------	-------	-------	--------

Center-to-face dimensions acc. to API 526 (dedicated to API-Orifice)											
Body size		D, E	F	G	H	J	L	M	P	Q	R
I	(mm)	114,3	120,7	120,7	123,8	123,8	165,1	184,2	228,6	241,3	266,7
I1	(mm)	104,8	123,8	123,8	130,2	136,5	155,6	177,8	181	239,7	239,7

Dimensions											
d0	(mm)	22,5	29	29	36	45	58,5	90	90	106	125
A0	(mm ²)	398	661	661	1018	1590	2688	6362	6362	8825	12272
H	(mm)	280	330	330	390	435	545	690	690	845	890
H (with stainless steel bellows)	(mm)	335	390	390	445	500	620	808	808	919	953
X	(mm)	150	200	200	250	300	350	500		500	500
C (Width of support tongues)	(mm)	--	--	--	--	204	242	332		362	405
Drainhole with plug	(inch)	G1/4"					G3/8"				
	Optional, not standard										

Weights											
Standard	(kg)	12	18	18	23	30	47	80	82	140	170
Option: stainless steel bellows	(kg)	13,5	20	20	25,5	34	54	90	92	155	185

Standard-flange dimensions												Flanges acc. to ASME / ANSI B16.5	
ØD1	ANSI150	(mm)	108	127	127	127	153	191	229		280	280	
	ANSI300	(mm)	124	156	156	156	165	210	254		318	318	
ØD2	ANSI150	(mm)	153	153	178	191	191	229	280		343	407	
b1	ANSI150	(mm)	17,5	20,6	20,6	20,6	22,3	28,6	31,8		36,5	36,5	
	ANSI300	(mm)	17,5	20,6	20,6	20,6	22,3	28,6	31,8		36,5	36,5	
b2	ANSI150	(mm)	19,1	19,1	22,3	23,8	23,8	23,8	25,4		28,6	30,2	

Standard-Flangeholes											
NPS		1"	1 1/2"	2"	2 1/2"	3"	4"	6"	8"	10"	
ØK	ANSI150	(mm)	79	98	120,5	140	152,5	190,5	241,5	298,5	362
n x Ød		(mm)	4 x 16	4 x 16	4 x 19	4 x 19	4 x 19	8 x 19	8 x 22	8 x 22	12 x 25
ØK	ANSI300	(mm)	89	114,5	127	--	168	200	270	--	--
n x Ød		(mm)	4 x 19	4 x 22	8 x 19	--	8 x 22	8 x 22	12 x 22	--	--

NPS	1"x2"	1 1/2"x2" 1 1/2"x2 1/2"	1 1/2"x3"	2"x3"	3"x4"	4"x6"	6"x8"	6"x10"
-----	-------	----------------------------	-----------	-------	-------	-------	-------	--------

Spring ranges: Standard design												
Full lift safety valve Fig. 901902/911/912	(barü)	0,2 - 0,5					0,2 - 0,5		0,2 - 0,4		0,2 - 0,5	
	(barü)	> 0,5 - 1					> 0,5 - 1		> 0,4 - 0,75		> 0,5 - 1	
	(barü)	> 1 - 1,5					> 1 - 1,5		> 0,75 - 1,1		> 1 - 1,5	
	(barü)	> 1,5 - 2					> 1,5 - 2		> 1,1 - 1,5		> 1,5 - 1,9	
	(barü)	> 2 - 2,7					> 2 - 2,5		> 1,5 - 1,9		> 1,9 - 2,3	
	(barü)	> 2,7 - 3,6					> 2,5 - 3		> 1,9 - 2,5		> 2,3 - 2,7	
	(barü)	> 3,6 - 5					> 3 - 3,6		> 2,5 - 2,95		> 2,7 - 3,3	
	(barü)	> 5 - 9					> 3,6 - 5		> 2,95 - 4		> 3,3 - 4,1	
	(barü)	> 9 - 16					> 5 - 9		> 4 - 5,7		> 4,1 - 5,5	
	(barü)	> 16 - 22					> 9 - 14		> 5,7 - 8,2		> 5,5 - 7,4	
	(barü)	> 22 - 28					> 14 - 19		> 8,2 - 12		> 7,4 - 11	
	(barü)	> 28 - 34					> 19 - 24		> 12 - 17		> 11 - 16	
	(barü)	> 34 - 40							> 17 - 24		> 16 - 21	
(barü)								> 24 - 27		> 21 - 26		

Spring ranges: Stainless steel bellows (optional)											
Standard safety valve Fig. 901/911	(barü)	2,5 - 3,3	2,5 - 3,2	2,6 - 3,6	2,8 - 3,4	2,5 - 3,7	2,5 - 3,5	1,1 - 1,5	1,1 - 1,3		
	(barü)	> 3,3 - 4,6	> 3,3 - 4	> 3,6 - 4,5	> 3,4 - 4,5	> 3,7 - 4,6	> 3,5 - 4,2	> 1,5 - 2	> 1,3 - 1,7		
	(barü)	> 4,6 - 5,4	> 4 - 5,5	> 4,5 - 5,6	> 4,5 - 8,4	> 4,6 - 5,9	> 4,2 - 4,9	> 2 - 2,5	> 1,7 - 2,1		
	(barü)	> 5,4 - 7	> 5,5 - 6,4	> 5,6 - 7,5	> 8,4 - 10	> 5,9 - 8	> 4,9 - 5,6	> 2,5 - 2,9	> 2,1 - 2,4		
	(barü)	> 7 - 9	> 6,4 - 7,9	> 7,5 - 10	> 10 - 11,5	> 8 - 10	> 5,6 - 7	> 2,9 - 3,5	> 2,4 - 2,8		
	(barü)	> 9 - 11,7	> 7,9 - 11,5	> 10 - 12,5	> 11,5 - 16	> 10 - 18	> 7 - 8	> 3,5 - 4,2	> 2,8 - 3,1		
	(barü)	> 11,7 - 16	> 11,5 - 18,5	> 12,5 - 16	> 16 - 18,5	> 18 - 24	> 8 - 9,3	> 4,2 - 5,1	> 3,1 - 3,4		
	(barü)	> 16 - 22	> 18,5 - 25	> 16 - 22	> 18,5 - 23	> 24 - 26	> 9,3 - 11,5	> 5,1 - 6,5	> 3,4 - 3,9		
	(barü)	> 22 - 30					> 11,5 - 14	> 6,5 - 7,5	> 3,9 - 4,8		
	(barü)						> 14 - 20	> 7,5 - 9	> 4,8 - 5,8		
	(barü)							> 9,0 - 10,5	> 5,8 - 6,8		
	(barü)							> 10,5 - 12,6	> 6,8 - 8,1		
	(barü)							> 12,6 - 17	> 8,1 - 9,7		
	(barü)							> 17 - 25	> 9,7 - 11,3		
	(barü)								> 11,3 - 13		
	(barü)								> 13 - 15		
(barü)								> 15 - 18			

Capacity saturated steam (incl. 10% overpressure)

NPS		1"x2"	1 1/2"x2"	1 1/2"x2 1/2"	1 1/2"x3"	2"x3"	3"x4"	4"x6"	6"x8"	6"x10"
Set pressure		Saturated steam kg/h								
0,2	(barg)	126	210	210	324	506	855	2024	2510	3490
0,4	(barg)	185	307	307	473	739	1250	2960	3630	5050
0,5	(barg)	207	344	344	529	827	1400	3310	4070	5660
0,6	(barg)	230	383	383	590	923	1560	3690	4470	6220
0,8	(barg)	272	453	453	698	1090	1840	4360	5240	7280
1	(barg)	317	526	526	811	1270	2140	5070	6030	8385
1,5	(barg)	425	707	707	1090	1700	2875	6800	8050	11200
2	(barg)	477	792	792	1220	1900	3220	7625	10125	14080
2,5	(barg)	572	950	950	1460	2285	3865	9145	11990	16660
3	(barg)	662	1100	1100	1695	2645	4475	10600	13880	19300
4	(barg)	837	1390	1390	2140	3350	5650	13400	17550	24400
5	(barg)	1000	1665	1665	2565	4000	6770	16000	21000	29250
6	(barg)	1165	1940	1940	2990	4665	7890	18650	24500	34050
7	(barg)	1330	2210	2210	3400	5320	9000	21300	27900	38800
8	(barg)	1495	2485	2485	3820	5980	10100	23900	31350	43600
9	(barg)	1660	2755	2755	4245	6630	11200	26500	34800	48400
10	(barg)	1820	3025	3025	4665	7290	12300	29150	38250	53200
11	(barg)	1985	3300	3300	5080	7940	13400	31750	41600	58000
12	(barg)	2150	3570	3570	5500	8590	14500	34350	45100	62700
13	(barg)	2310	3840	3840	5920	9250	15600	37000	48500	67500
14	(barg)	2475	4110	4110	6340	9900	16700	39600	52000	72300
15	(barg)	2640	4385	4385	6760	10550	17800	42200	55400	77000
16	(barg)	2800	4655	4655	7170	11200	18950	44800	58800	81800
17	(barg)	2965	4930	4930	7590	11850	20050	47400	62200	86600
18	(barg)	3130	5200	5200	8010	12500	21150	50100	65700	91400
19	(barg)	3295	5470	5470	8430	13150	22250	52700	69100	96200
20	(barg)	3460	5750	5750	8850	13800	23350	55300	72600	101000
21	(barg)	3620	6020	6020	9250	14500	24500	57900	76000	105800
22	(barg)	3790	6290	6290	9700	15150	25600	60600	79500	110900
24	(barg)	4120	6840	6840	10500	16450	27850	65900	86500	120600
25	(barg)	4280	7120	7120	10950	17100	28950		90200	125500
26	(barg)	4450	7390	7390	11350	17800	30050		93700	130300
27	(barü)	4620	7670	7670	11820	18460	31220		96950	
28	(barg)	4780	7950	7950	12250	19100	32300			
30	(barg)	5120	8500	8500	13100	20450	34550			
32	(barg)	5450	9060	9060	13950	21800	36800			
34	(barg)	5800	9650	9650	14850	23250	39100			
40	(barg)									

↓ max. set pressure stainless steel version

Capacity air (incl. 10% overpressure)

NPS		1"x2"	1 1/2"x2"	1 1/2"x2 1/2"	1 1/2"x3"	2"x3"	3"x4"	4"x6"	6"x8"	6"x10"
Set pressure		Air in Nm ³ /h (0°C; 1,013 bara)								
0,2	(barg)	148	246	246	380	594	1003	2375	2945	4100
0,4	(barg)	223	370	370	570	891	1505	3565	4380	6090
0,5	(barg)	252	419	419	646	1009	1705	4035	4970	6910
0,6	(barg)	284	472	472	728	1135	1920	4545	5520	7675
0,8	(barg)	341	567	567	873	1365	2305	5460	6555	9115
1	(barg)	398	661	661	1019	1590	2690	6370	7575	10530
1,5	(barg)	538	894	894	1378	2150	3640	8610	10195	14180
2	(barg)	607	1008	1008	1550	2425	4100	9700	12890	17920
2,5	(barg)	731	1215	1215	1870	2925	4945	11700	15330	21300
3	(barg)	850	1410	1410	2175	3400	5750	13600	17840	24800
4	(barg)	1080	1800	1800	2770	4330	7310	17300	22725	31600
5	(barg)	1300	2160	2160	3330	5210	8800	20840	27350	38000
6	(barg)	1520	2530	2530	3900	6090	10300	24370	31900	44400
7	(barg)	1745	2900	2900	4465	6970	11790	27900	36600	50900
8	(barg)	1965	3260	3260	5030	7860	13280	31430	41200	57300
9	(barg)	2185	3630	3630	5590	8740	14770	34960	45800	63800
10	(barg)	2400	3990	3990	6150	9610	16250	38500	50500	70200
11	(barg)	2625	4360	4360	6720	10500	17750	42000	55100	76600
12	(barg)	2845	4730	4730	7290	11380	19240	45500	59700	83100
13	(barg)	3070	5090	5090	7850	12270	20730	49000	64400	89500
14	(barg)	3290	5460	5460	8400	13150	22200	52600	69000	96000
15	(barg)	3500	5830	5830	8980	14030	23700	56100	73600	102400
16	(barg)	3725	6190	6190	9540	14900	25200	59600	78200	108800
17	(barg)	3950	6560	6560	10100	15800	26700	63100	82900	115300
18	(barg)	4170	6920	6920	10670	16650	28100	66700	87500	121700
19	(barg)	4390	7300	7300	11240	17550	29600	70200	92100	128100
20	(barg)	4610	7660	7660	11800	18400	31150	73700	96800	134600
21	(barg)	4830	8020	8020	12370	19300	32650	77300	101400	141000
22	(barg)	5050	8390	8390	12930	20200	34150	80800	106000	147500
24	(barg)	5490	9120	9120	14060	21970	37100	87900	115300	160400
25	(barg)	5710	9490	9490	14620	22850	38600		120000	166900
26	(barg)	5930	9850	9850	15190	23730	40100		124600	173300
27	(barü)	6160	10240	10240	15770	24630	41650		129350	
28	(barg)	6370	10600	10600	16320	25500	43100			
30	(barg)	6810	11320	11320	17450	27250	46100			
32	(barg)	7250	12050	12050	18570	29000	49100			
34	(barg)	7700	12790	12790	19700	30800	52050			
40	(barg)	9030	14477	14477	23810	36100	61000			

max. set pressure stainless steel version

Capacity water (incl. 10% overpressure)

NPS		1"x2"	1 1/2"x2"	1 1/2"x2 1/2"	1 1/2"x3"	2"x3"	3"x4"	4"x6"	6"x8"	6"x10"	
Set pressure		Water m ³ /h									
max. set pressure stainless steel version	0,2 (barg)	5,13	8,53	8,53	13,1	20,5	30,8	73	94,9	132	
	0,5 (barg)	8,12	13,5	13,5	20,8	32,5	48,8	115	150	209	
	1 (barg)	11,5	19,1	19,1	29,4	45,9	69	163	212	295	
	2 (barg)	16,2	27	27	41,6	64,9	97,5	231	300	417	
	3 (barg)	19,9	33	33	50,9	79,5	119	283	368	511	
	4 (barg)	22,9	38,1	38,1	58,7	91,8	138	326	424	590	
	5 (barg)	25,7	42,6	42,6	65,5	102	154	365	474	660	
	6 (barg)	28,1	46,7	46,7	72	112	169	400	520	723	
	7 (barg)	30,4	50,4	50,4	77,7	121	182	432	562	781	
	8 (barg)	32,5	53,9	53,9	83,1	130	195	461	600	835	
	9 (barg)	34,4	57,2	57,2	88,1	138	207	490	637	885	
	10 (barg)	36,3	60,3	60,3	92,9	145	218	516	671	933	
	11 (barg)	38	63,2	63,2	97,4	152	229	540	703	977	
	12 (barg)	39,7	66	66	102	159	239	565	735	1022	
	13 (barg)	41,4	68,7	68,7	106	165	249	587	764	1062	
	14 (barg)	42,9	71,3	71,3	110	172	258	611	794	1104	
	16 (barg)	45,9	76,3	76,3	117	184	276	653	849	1181	
	18 (barg)	48,7	80,9	80,9	125	195	293	692	900	1252	
	19 (barg)	49,9	82,9	82,9	128	200	300	710	923	1284	
	20 (barg)	51,3	85,3	85,3	131	205	308	730	949	1320	
21 (barg)	52,6	87,4	87,4	135	210	316	748	973	1350		
24 (barg)	56,2	93,4	93,4	144	225	338	800	1040	1443		
25 (barg)	57,4	95,3	95,3	147	229	345		1059	1473		
26 (barg)	58,5	97,2	97,2	150	234	352		1080	1502		
27 (barg)	59,6	99	99	153	238	358		1100			
28 (barg)	60,7	101	101	155	243	365					
30 (barg)	62,9	104	104	161	251	375					
32 (barg)	64,8	108	108	166	259	390					
34 (barg)	66,9	111	111	171	268	400					
40 (barü)	72,5	124,8	124,8	185,4	289,7	435					