

THERMODYNAMIC STEAM TRAPS DT46

DESCRIPTION

Thermodynamic DT46 disc steam traps are compact and lightweight-easy to install traps, excellent for high pressure systems, including steam tracing applications.

The insulation cover insures a consistent operation and makes it particularly suitable for those applications where the weather conditions, such as rain and wind, may affect the normal operation.

These traps have only one moving part and offer a wide operating range, without adjustment.

Connections are female screwed or flanged.

MAIN FEATURES

Intermittent discharge.

Standard insulation cover

Operates on superheated steam.

The seat and disc can be easily replaced in field without removing the trap from the line.

Unaffected by water hammer and vibrations

Built-in easy-to-clean strainer.

OPTIONS: Blowdown valve
USE: Saturated and superheated steam.

AVAILABLE MODELS:

DT 46

SIZES: DN ½" to DN 1" – DN15 to DN25

CONNECTIONS: Female screwed ISO7/1 Rp (BS21)
Flanged EN1092-1 PN40-PN100 or ANSI

INSTALLATION: Horizontal installation recommended.
Can be installed in any position.

APPLICATION

LIMITS: Min. working pressure – 1,5 bar
Max. working back pressure – 80%



(Threaded – nickel plated)



(Flanged and SW
black painted)

BODY LIMITING CONDITIONS					
FLANGED PN 40 */ ANSI 300 **	FLANGED ANSI 150# **	FLANGED PN 63 *	FLANGED PN 100 *	FLANGED ANSI 600# **	RELATED TEMP.
ALLOW. PRES.	ALLOW. PRES.	ALLOW. PRES.	ALLOW. PRES.	ALLOW. PRES.	
40 bar	19,3 bar	63 bar	100 bar	90,5 bar	50 °C
37,1 bar	17,7 bar	58,5 bar	92,8 bar	80,2 bar	100 °C
33,3 bar	14 bar	52,5 bar	83,3 bar	72 bar	200 °C
27,6 bar	10,2 bar	43,5 bar	69 bar	59,7 bar	300 °C
23,8 bar	6,5 bar	37,5 bar	59,5 bar	51,4 bar	400 °C

PMO - Max. operating pressure 46 bar ; TMO - Max. operating temperature 400 °C

* According to EN1092-1:2007 ; ** Acc. to EN1759-1:2004

Body limiting conditions PN100 or below , depending on the type of connection adopted. Rating PN100 for thread, SW and BW.

FLOW RATE CAPACITY IN Kgs/h															
MODEL	SIZE DN	DIFFERENTIAL PRESSURE (bar)													
		1,5	3	5	7	9	12	15	18	21	24	30	35	42	46
DT 46 (Hot)	1/2"-15 1"-25	70	100	130	175	190	200	225	240	250	270	290	300	310	320
DT 46 (Cold)	1/2"-15 1"-25	170	230	300	335	390	435	485	520	575	600	645	695	740	800

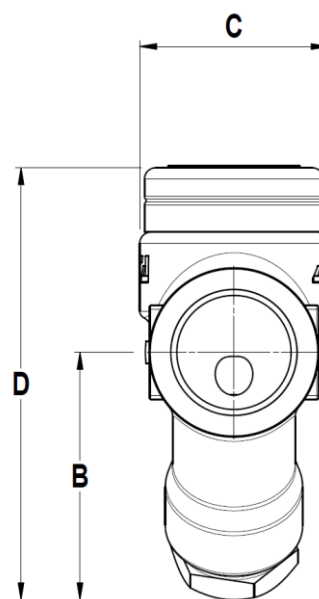
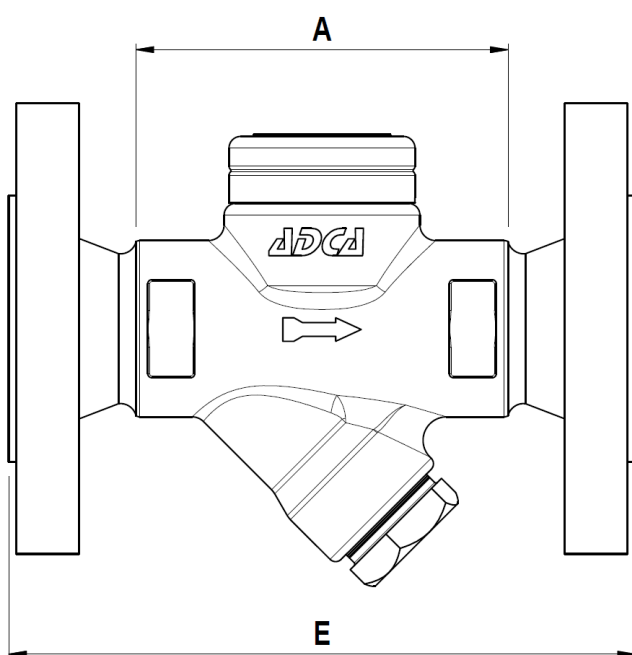

DIMENSIONS (mm)													
Screwed and SW *						EN PN16/PN40		EN PN63		ANSI 150		ANSI 300	
SIZE DN	A	B	C	D	WGT. Kgs	E	WGT. Kgs	E	WGT. Kgs	E	WGT. Kgs	E	WGT. Kgs
15-1/2"	95	60	50	109	1,3	150	2,8	150	3,7	150	3,9	150	4,9
20-3/4"	95	60	50	109	1,2	150	3,3	150	5,2	150	4,8	150	7
25-1"	95	66	50	115	1,5	160	4,1	160	6,7	160	6,5	160	8,5

* BW (butt weld) on request.

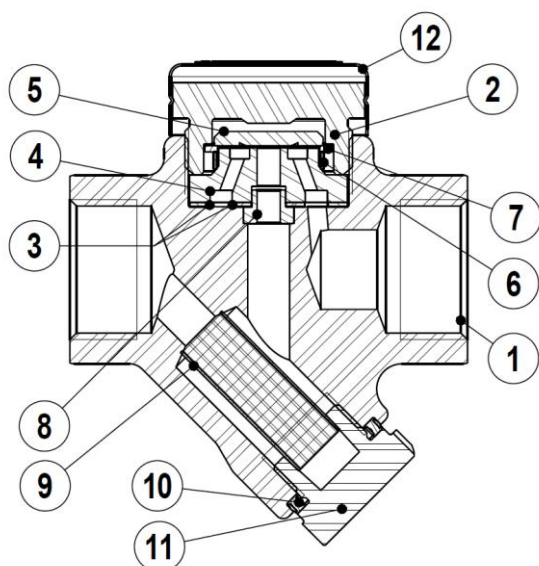

MATERIALS		
POS.Nr.	DESIGNATION	MATERIAL
1	Body	P250GH / 1.0460
2	Cover	AISI 304 / 1.4301 AISI 303 / 1.4305
3	*Gasket	StainlessSt./Graphite
4	*Seat	Hardened St.Steel
5	*Valve disc	Hardened St.Steel
6	*Bimetal ring	Bimetal
7	*Washer support	AISI 304 / 1.4301
8	*Tube	AISI 304 / 1.4301
9	*Strainer screen	AISI 304 / 1.4301
10	*Gasket	StainlessSt./Graphite
11	Plug	A105 / 1.0432
12	Insulation cover	AISI 304 / 1.4301

*Available spare parts.

MAIN STANDARD FEATURES

Insulation cover

Reduces heat losses, mainly where weather conditions, such as rain and wind, may affect the normal operation

Automatic air vent

Faster response during start-up, avoiding air blockage

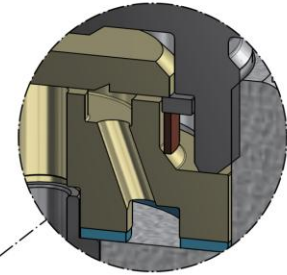

Blow-out resistance seat gaskets

Graphite based endowed with mechanical reinforcement and anti-stick properties, particularly efficient for high pressure/temperature applications.

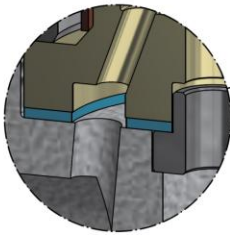

Hardened valve and disc

Duly lapped (mirror finished), guarantee longer service life

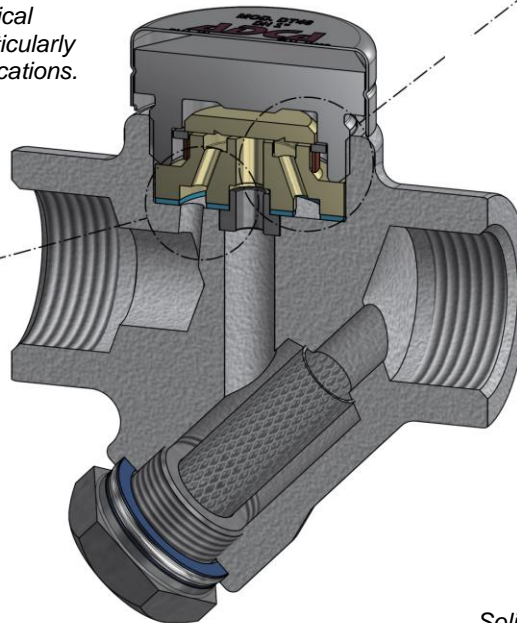

Easy maintenance

Seat and disc are replaceable

Strong design

Solid and compact forged steel design, ensures increased life

Strainer

Integral stainless steel strainer

Strainer gasket

Spiral wound stainless steel/graphite strainer gasket